



**FLEXIBLE VENTING OPTIONS**

- Concentric or Schedule 40 PVC/CPVC
- Direct Vent (Concentric and Twin Pipe)
- Non-Direct Vent (Room Air)
- Common Vent (Direct Vent and Room Air)
- Maximum Equivalent Vent Lengths:

Twin Pipe

Vent Sizes	2 in. (51 mm)	3 in. (76 mm)
Vent Lengths	65 ft (20 m)	150 ft (46 m)

Concentric

Vent Sizes	2 in. X 4 in.	3 in. X 5 in.
Vent Lengths	65 ft (20 m)	150 ft (46 m)

**EASE OF INSTALLATION AND SERVICEABILITY**

- Compact Design to Save Space
- Wi-Fi Technology for Remote Monitoring and Management
- Sliding Mounting Bracket for Easy Installation
- Simple Gas Conversion

**OPTIONAL ACCESSORIES**

Room Air Screen, Condensate Neutralizer, ScaleCutter, Drain Down Kit, Additional Controllers, Pipe Cover, Recirculation Pump, DPS/MIS Switch, EZConnect™ Cables, Control-R™ Wi-Fi Module, Wireless Accessories, and many more. Visit [rinnai.us](http://rinnai.us) for a complete list of accessories.

**SUPER-HIGH-EFFICIENCY (CONDENSING) TANKLESS WATER HEATER**

<b>Installation Type</b>	Internal (Indoor) Residential Applications. Manufactured (Mobile) Home Certified	
<b>Model Numbers</b>	RU199i (REU-N3237FF-US) RU180i (REU-N2934FF-US) RU160i (REU-N2530FF-US) RU130i (REU-N2024FF-US)	
<b>Approved Gas Types</b>	Natural and Propane	
<b>Uniform Energy Factor (UEF)</b>	RU199i, RU180i, RU160i:	0.93
	RU130i:	0.91
<b>Energy Factor (EF) (Canada)</b>	RU199i:	0.96
	RU180i, RU160i, RU130i:	0.95
<b>High Altitude Approved</b>	Up to 10,200 ft (3,109 m)	
<b>Water Flow Control</b>	Water Flow Sensor, Electronic Water Control and Bypass Control	
<b>Controller</b>	Standard: Integrated Controller Optional: MC-195T-US, MC-100V-1US, BC-100V-1US, MCC-91-2US	
<b>Certifications</b>	AHRI, ANSI Z21.10.3, CSA 4.3, and ENERGY STAR®	

**Warranty**

- Heat Exchanger: 15 years or 12,000 operation hours, whichever occurs first
- All Other Parts and Components: 5 Years
- Reasonable Labor: 1 Year

**Safety Devices**

Flame Failure - Flame Rod, Boiling Protection, Combustion Fan RPM Check, Over Current - Glass Fuse, Remaining Flame (OHS) and Automatic Frost Protection

**Included with Purchase**

Tankless Water Heater, Wall Mounting Bracket, Pressure Relief Valve and Adapter, Isolation Valve Kit, Vent Screens (x2), Vent Screen Screws (x2) and Self-Tapping Screws (x2)

**Additional Features**

- Mobile Home Certified
- Ultra Low NOx
- Complies with South Coast Air Quality Management District 14 ng/J or 20 ppm NOx Emission Levels
- Tankless Rack System™ Compatible
- 1/2 in. (13 mm) Gas Line Compatible



CERTIFIED TO ANSI Z21.10.3 — CSA 4.3

# SENSE™ TECHNICAL SPECIFICATIONS

SPECIFICATION		RU199i	RU180i	RU160i	RU130i
Dimensions - w, h, d		18.5 in. x 26.4 in. x 11.4 in. (470 mm x 670 mm x 290 mm)			
Minimum Gas Consumption Btu/h		15,000			
Maximum Gas Consumption Btu/h		199,000	180,000	160,000	130,000
Flow Rate <sup>1</sup> (Min - Max)		0.26 - 9.8 GPM (1.0 - 37 L/min)	0.26 - 9.0 GPM (1.0 - 34 L/min)	0.26 - 8.0 GPM (1.0 - 30 L/min)	0.26 - 6.6 GPM (1.0 - 24 L/min)
Max Flow Rate with Parameter Adjustment		11 GPM (42 L/min)	10 GPM (38 L/min)	9 GPM (34 L/min)	7 GPM (26 L/min)
Weight		64 lb (29 kg)	64 lb (29 kg)	62 lb (28 kg)	62 lb (28 kg)
Sound Level		48 dB	47 dB	47 dB	47 dB
Electrical	Normal	84 W	65 W	52 W	38 W
	Standby	1.3 W			
	Freeze Protection	148 W			
	Max Current	4 Amps			
	Fuse	10 Amps			
Temperature		<ul style="list-style-type: none"> <li>Minimum: 98° F (37° C) Default</li> <li>Maximum: 120° F (49° C) Default</li> <li>140° F (60° C) With Parameter Adjustment</li> </ul>			
By-Pass Flow Control		Electronic			
Gas Supply Pressure <sup>2</sup>		<ul style="list-style-type: none"> <li>Natural: 3.5 in. w.c. - 10.5 in. w.c.</li> <li>Propane: 8.0 in. w.c. - 13.5 in. w.c.</li> </ul>			
Ignition System		Direct Electronic Ignition			
Electronic Connections		<ul style="list-style-type: none"> <li>Appliance: AC 120 Volts, 60Hz.</li> <li>Temperature Controller: DC 12 Volts (Digital)</li> </ul>			
Water Supply Pressure		<ul style="list-style-type: none"> <li>Minimum: 50 PSI (Recommended 60-80 PSI for max performance)</li> <li>Maximum: 150 PSI</li> </ul>			
Controller Cable		Non-Polarized Two Core Cable (Minimum 22 AWG)			
Service Connections		<ul style="list-style-type: none"> <li>Gas Supply: 3/4 in. (19 mm) NPT</li> <li>Cold Water Inlet: 3/4 in. (19 mm) NPT</li> <li>Hot Water Outlet: 3/4 in. (19 mm) NPT</li> <li>Condensate Drain: 1/2 in. (13 mm) NPT</li> </ul>			
Clearances		<ul style="list-style-type: none"> <li>Top: 2 in. (51 mm)*</li> <li>Bottom/Ground: 12 in. (305 mm)</li> <li>Front: 0 in.**</li> <li>Back: 0 in.</li> <li>Sides: 2 in. (51 mm)***</li> <li>Vent: 0 in.</li> </ul>			

\* 0 in. from vent components  
 \*\* Clearance for servicing is 24 in. (610 mm) in front of water heater  
 \*\*\* Add 0.25 in. (6.35 mm) for recess box

<sup>1</sup> Minimum flow may vary slightly depending on the temperature setting and the inlet water temperature. Minimum activation flow is 0.4 GPM (1.5 L/min).  
<sup>2</sup> The maximum gas supply pressure must not exceed the value specified by the manufacturer.

# SENSE™ WATER FLOW CURVE

Flow curves apply only to incoming water temperatures of 70° F (21° C) or less. For incoming water temperatures greater than 70° F (21° C), please contact Rinnai.

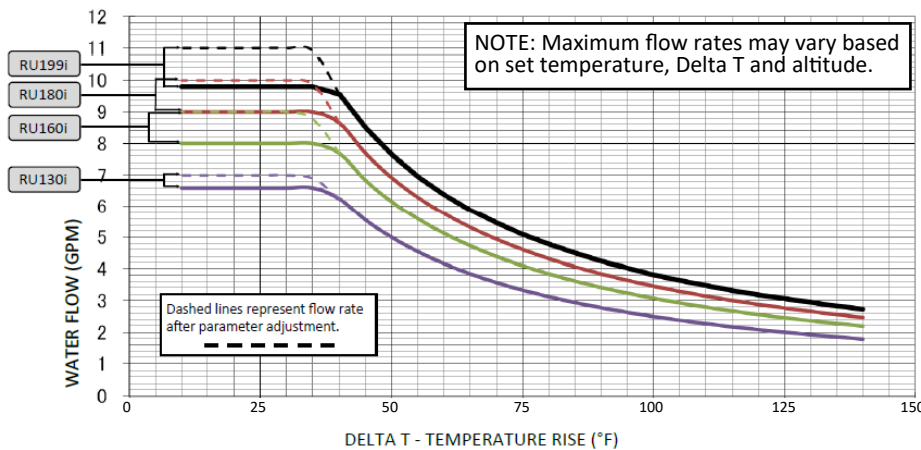

# SENSE™ DIMENSIONS

in. (mm)

## FRONT

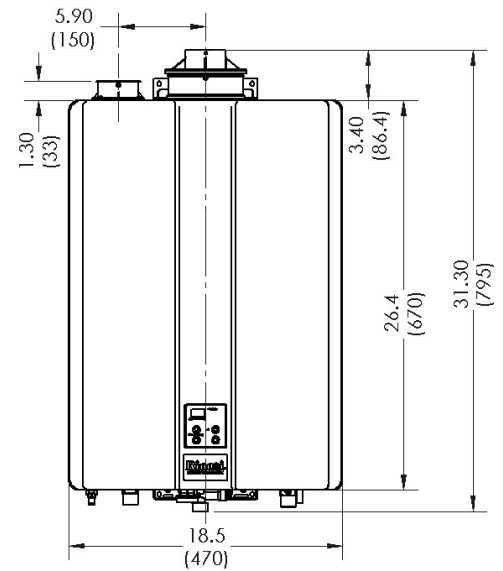

## SIDE

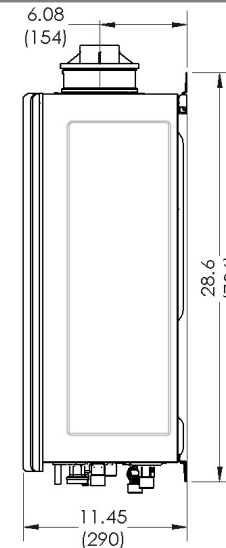

### Vent Connection:

2 in. (51 mm) nominal PVC/Polypropylene or 3 in./5 in. Concentric.

## BOTTOM

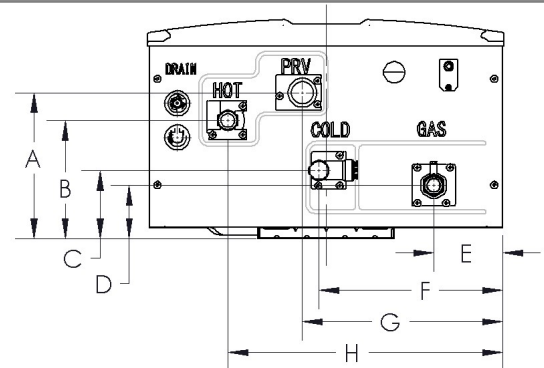

Connection		in.	mm
COLD	F	9.54	242
	C	3.56	90
HOT	H	14.27	362
	B	6.16	156
GAS	E	3.57	91
	D	2.78	71
PRV	G	10.39	264
	A	7.60	193